



Alfa Laval Aseptic Mixproof

Double seat valves

Introduction

The Alfa Laval Aseptic Mixproof Valve is an advanced double block-and-bleed mixproof valve for use in hygienic and aseptic processes that demand a contaminant-free environment. The valve enables the simultaneous flow of two different products or fluids through the same valve without the risk of cross-contamination. Its one-piece diaphragm ensures hermetic sealing and prevents intrusion from the atmosphere, even during unwanted pressure spikes.

With a flexible, modular design, the Aseptic Mixproof Valve is easy to configure in Alfa Laval Anytime to meet virtually any process requirement. Choose from a broad range of components, including seat lift, temperature sensor or transmitter. Plus its design makes maintenance quick and easy, thereby reducing the total cost of ownership to the lowest level possible compared to other aseptic valves.

Application

This aseptic double-seat mixproof valve is designed for use in aseptic process applications across the dairy, food, beverage, and many other industries.

Benefits

- Exceptional hygiene for maximum product safety and minimal product loss
- Outstanding flexibility and modularity to meet virtually any requirement
- More uptime due to exceptional cleanability
- Up to 45% lower total cost of ownership compared to other aseptic valves
- Ease of maintenance and parts replacement

Standard design

The Alfa Laval Aseptic Mixproof Valve is a normally closed (NC) valve controlled from a remote location by means of compressed air. An integrated valve plug/diaphragm ensures aseptic operation. There is a total of four valves: two main product valves, which are normally closed (NC), and two small leakage detection valves, which are either normally open/normally open (NO/NO) or normally closed/normally open (NC/NO). The valve can also be fitted with the Alfa Laval ThinkTop V50 and V70 for sensing and control of the valve.

Working principle

The Alfa Laval Aseptic Mixproof Valve is comprised of a series of base components, including valve body, valve plug/diaphragm, actuator, and cleaning options and accessories that support a wide range of aseptic applications. Composed of a PTFE face and reinforced EPDM backing, the diaphragm creates a hermetic seal to ensure aseptic processing conditions. Leakage detection holes enable visual inspection without requiring valve disassembly and provide advanced notification of parts wear. Few straightforward moveable parts contribute to reliable operation and reduced maintenance costs.

When main actuation takes place, all four valves operate simultaneously. The two product valves open and the two leakage detection valves close to prevent product spillage. Please observe the maximum allowable working pressure for diaphragms on the product valves.



The product lines are separated by two individual plugs (two normally closed valves) and a sterile leakage chamber that acts as a barrier to prevent product mixing and to provide immediate indication of any leakage from either of the two plug seals.

Two small leakage detection valves (NO/NO or NC/NO) control the flow of steam into and out of the leakage chamber; these must be kept clean and sterile when the main valves are closed. As an option, one of the two leakage detection valves can be supplied as a changeover valve to maintain the flow of steam, ensuring a continuous steam barrier in both leakage detection valves during the main actuation of the product valves.

A changeover valve may be used to control the steam flow in order to bypass the leakage chamber. On the steam-forward line, you can add an additional aseptic SSV valve to build up a condensate reservoir in order to flush the leakage chamber after main activation.

Certificates



TECHNICAL DATA

Temperature	
Temperature range:	-10°C to +140°C (EPDM)
Max. sterilization temperature (<1 min):	150°C/380 kPa (3.8 bar)

Pressure	
Pressure range:	0-800 kPa (0-8 bar)
Air pressure:	500-700 kPa (5-7 bar)
Pressure range, support air:	0-300 kPa / 0-3 bar

Note! Vacuum is not recommended in aseptic applications.

PHYSICAL DATA

Materials	
Product wetted steel parts:	1.4404 (316L)
Other steel parts:	1.4301 (304)

Surface finish	
External surface finish:	Semi-bright (blasted)
Internal surface finish:	Bright (polished), Ra < 0.8 µm

Seals	
Product wetted seals:	EPDM
Optional product wetted seals:	HNBR
Other seals:	NBR
Diaphragm:	PTFE (Product wetted side) / EPDM

Option	
Temperature sensor (PT100):	with or without transmitter
Steam valve	Hygienic or Aseptic

Sizes	
Main valve ISO:	51 mm; 63.5 mm; 76.1 mm

Shut fully closed. Max. static pressure without leakage

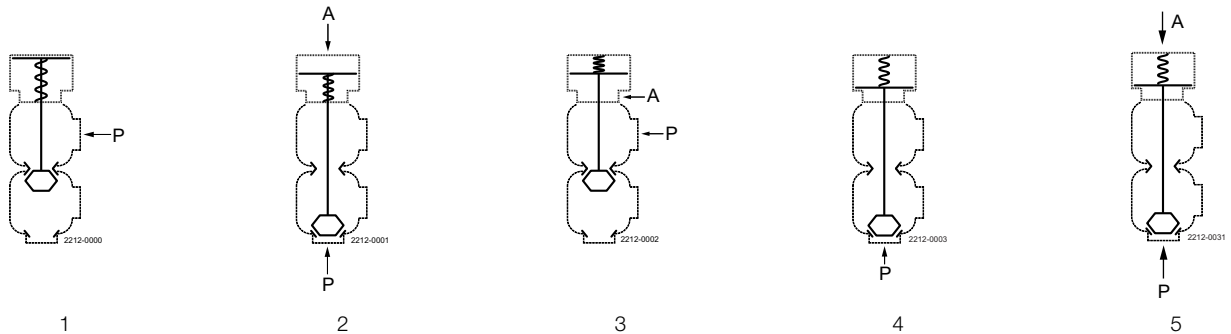

Actuator / Valve body combination and direction of pressure	Air pressure (bar)	Plug position	Valve size			
			Main valve			Leakage detection valve
			51mm	63.5mm	76.1mm	
1		NO				8 bar
2	6	NO				8 bar
3	6	NC				8 bar
4		NC	7.5 bar	4.5 bar	7 bar	8 bar
5*	3	NC	8 bar	8 bar	8 bar	8 bar

* support air

Pressure drop/capacity diagrams

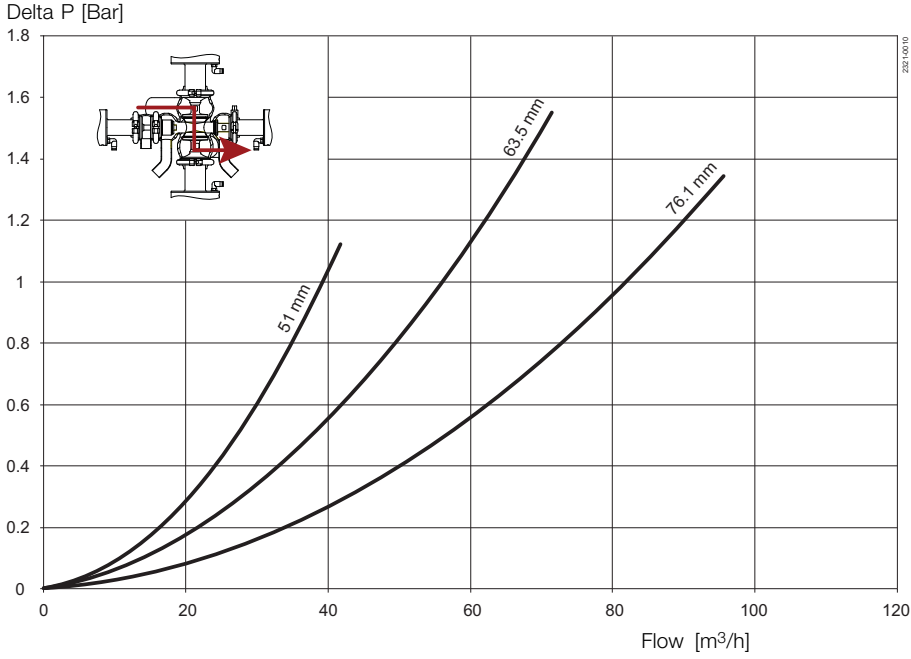

Seat lift

	Kv-Value
51 mm	3.1 m ³ /hr
63.5 mm	3.6 m ³ /hr
76.1 mm	4.1 m ³ /hr

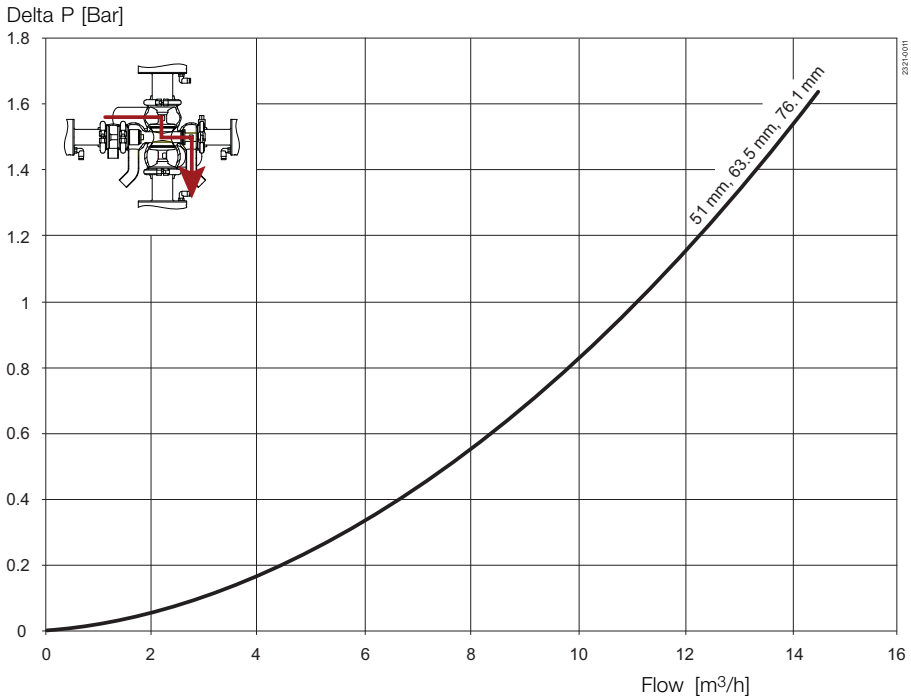

Dimensions (mm)

Note: Choose the version that is fully drainable in your installation setup.

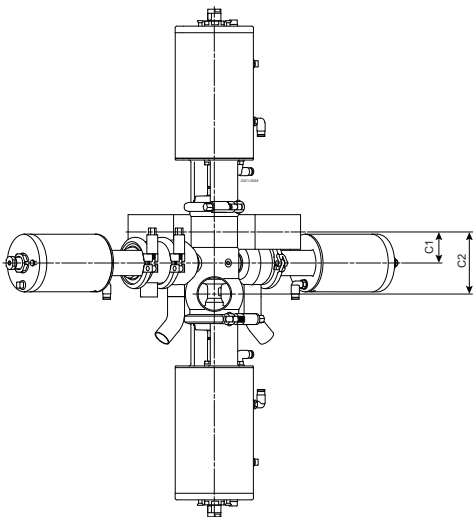
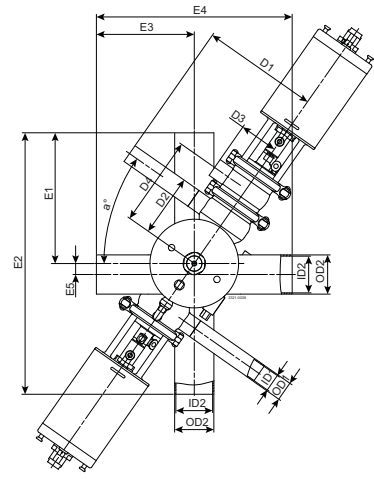
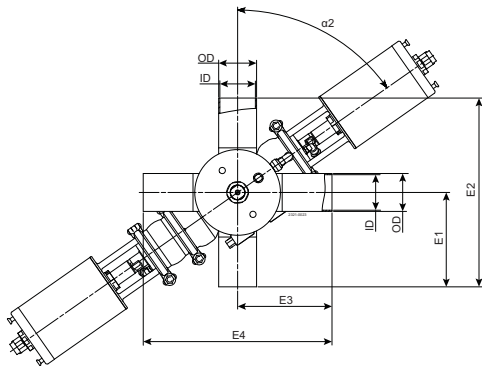
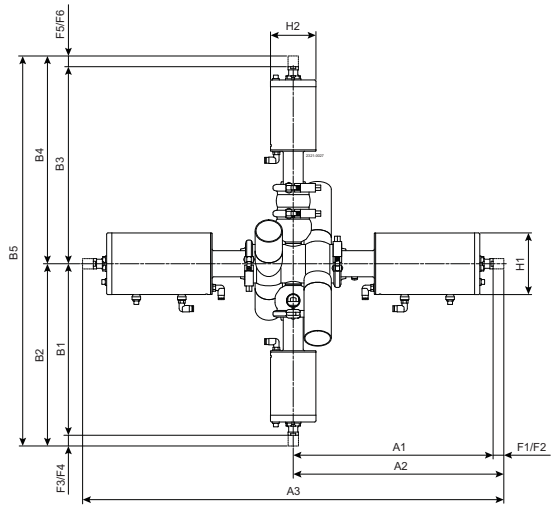
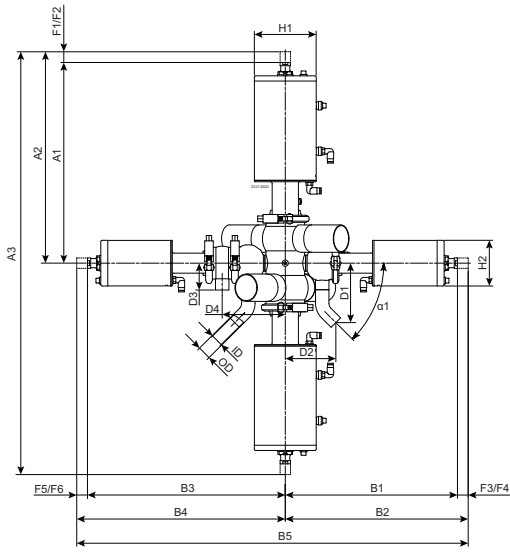

Vertical mount

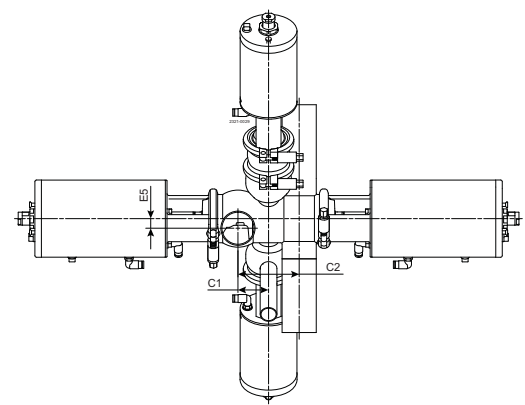

Horizontal mount

Size	51 mm	63.5 mm	76.1 mm	51 mm	63.5 mm	76.1 mm
	Vertical mount			Horizontal mount		
A1	374	386	440	374	386	440
A2	388	400	457	388	400	457
A3	776	801	914	776	801	914
B1	335	343	350	335	343	350
B2	350	358	366	350	358	366
B3	381	389	396	381	389	396
B4	391	399	407	391	399	407
B5	741	757	772	741	757	772
C1	45.7	52.0	58.3	45.7	52.0	58.3
C2	91.4	103.9	116.5	91.4	103.9	116.5
D1	110.7	110.7	110.7	172.5	172.5	172.5
D2	94.2	102.2	109.7	68.8	76.8	84.3
D3	50	50	50	50	50	50
D4	117.5	125.5	133.0	117.5	125.5	133.0
E1	127	133	139	170.0	216.0	226.0
E2	254	266	278	340.0	432.0	452.0
E3	127	133	139	127	133	139
E4	254	266	278	254	266	278
E5	-	-	-	14.4	18	21.6
$\alpha 1$	45°	45°	45°	-	-	-
$\alpha 2$	55°	55°	55°	55°	55°	55°
F1	14	14	17	14	14	17
F2	2	2	2	2	2	2
F3	10	10	10	10	10	10
F4	15	15	15	15	15	15
F5	8	8	8	8	8	8
F6	12	12	12	12	12	12
H1	115	115	157.5	115	115	157.5
H2	85	85	85	85	85	85
t1	1.2	1.2	1.2	1.2	1.2	1.2
t2	1.6	1.6	1.6	1.6	1.6	1.6
ID1	22.6	22.6	22.6	22.6	22.6	22.6
ID2	47.8	60.3	72.9	47.8	60.3	72.9
OD1	25	25	25	25	25	25
OD2	51	63.5	76.1	51	63.5	76.1
Weight (kg) (max)	29	30	45	29	30	45

Alfa Laval reserves the right to change specifications without prior notification.

How to contact Alfa Laval

Contact details for all countries
are continually updated on our website.
Please visit www.alfalaval.com to
access the information direct.